

BetterBook™ Solutions

Perfect binding adhesive systems for books that lie flatter, last longer and look better.

The diverse Nordson product line delivers flexibility to use:

- EVA or PUR hot melt adhesives
- Contact or non-contact adhesive application
- Open or closed application systems

Nordson® BetterBook binding solutions provide you with the best adhesive systems to produce consistent, high-quality perfect bound books. With more than 50 years of adhesive application experience, Nordson has a full range of products to meet your specific paper stock and adhesive bonding requirements for spine and side gluing applications.

Nordson bookbinding systems:

- **Provide consistent, reliable performance** with precise dispensing and clean cutoff.
- **Increase productivity** by reducing cleanup and shortening startup/shutdown times.
- **Deliver production flexibility** by being easily adjusted for changeovers and integrating into existing production lines.
- **Help lower production costs** by reducing waste and adhesive usage.

From small batches to a single Book-on-Demand...

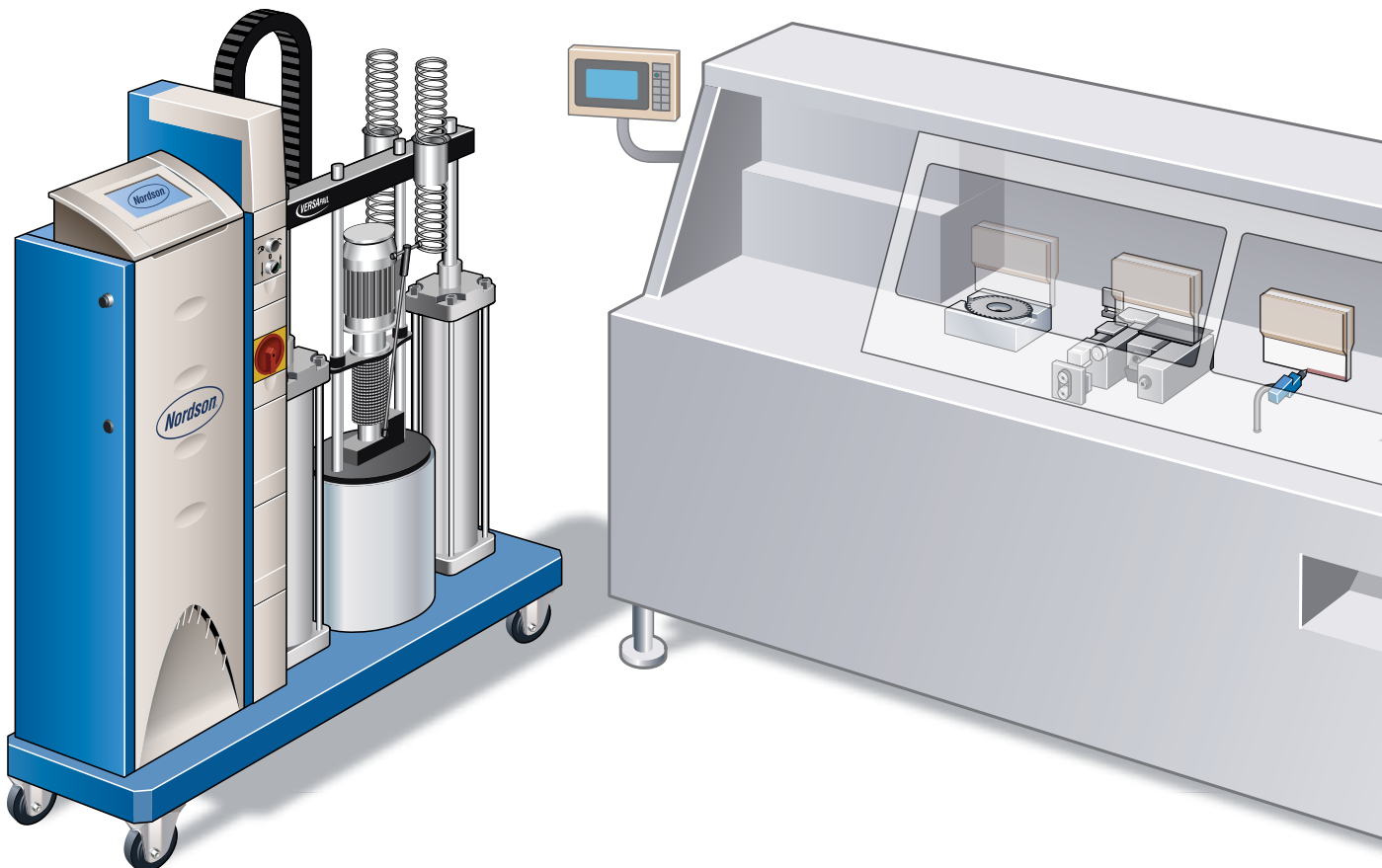



Nordson slot nozzle technology is adaptable to the parent machine requirements to allow fully-automatic integration and set-up.

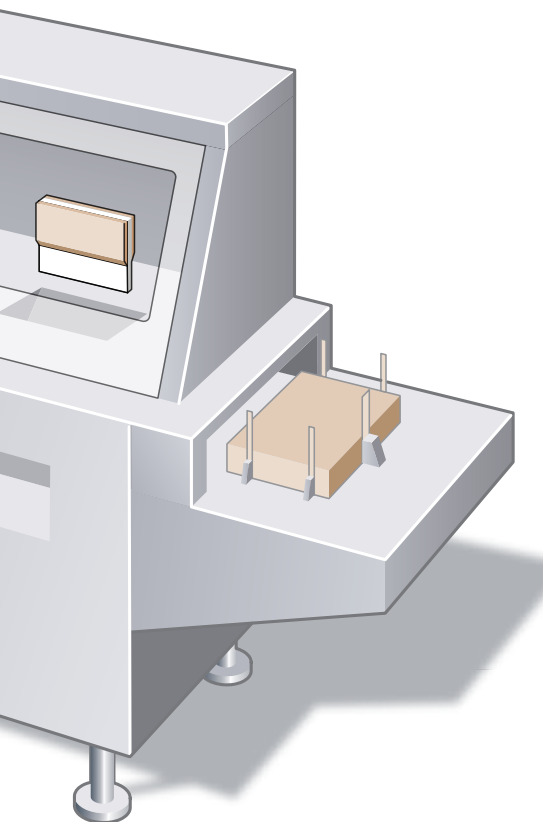

Spine Gluing

Nordson specializes in the use of polyurethane (PUR) adhesives for spine gluing applications. With systems to both dispense and verify adhesive patterns, Nordson helps you achieve a consistent adhesive bond even on difficult to bond cross-grain, aqueous or UV-coated papers, as well as on digital printed papers used in Xerox® iGen™ or HP® Indigo® printers.



Nordson slot nozzle technology delivers precision application using positive pressure and clean cutoff for consistent, reproducible spine coating thickness. The closed system helps reduce the daily cleanup, decrease the adhesive waste and shorten the startup/shutdown times associated with traditional open pot systems. As such, it is ideally suited for use in digital printing environments.

New Book-On-Demand (BoD) Applicator

The new patent-pending applicator is suitable for spine and/or side PUR adhesive application. The EP48-BoD applicator will result in faster, more flexible and more economical book production.

Benefits of EP48-BoD Applicator

- Supports true Books-on-Demand
 - Single book production
 - Application width 0 to 60 mm
- Use in-line or off-line
- Install on a new line or as a retrofit
- Has automatic set-up capability
- Improved maintenance features



Integrated Side Gluing

Special patented nozzles deliver precise adhesive placement and uniform film size to side gluing applications. This allows the flexibility to bind difficult materials and produce all PUR perfect bound books.

EVA side gluing is also available for faster setting.

Premelting

A wide range of bulk melters and premelters accommodate various adhesive requirements. Nordson melters utilize melt technologies that help protect adhesive integrity and optimize dispensing and bonding. Precision temperature controls and sensors maintain constant temperature for consistent viscosity and application control.



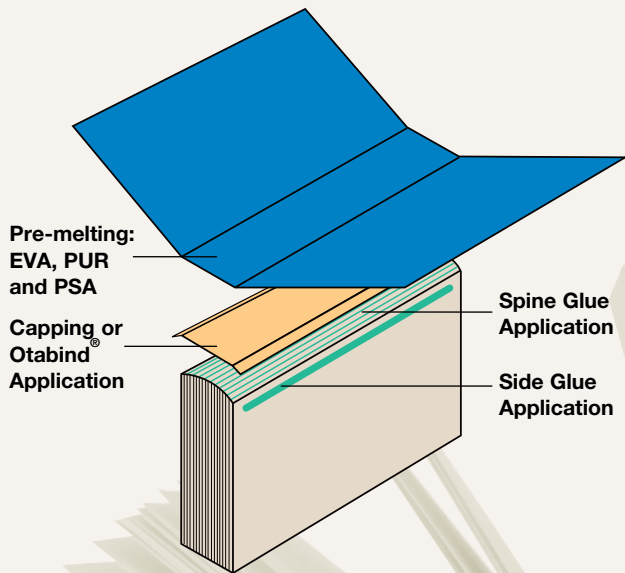

Bookbinding Applications

The Nordson bookbinding product portfolio includes specialized products that can be combined to create a bookbinding system that fully meets your production needs while delivering the best performance.

Features and Benefits

- **Improve book quality** with consistent adhesive application.
- **Increase production flexibility** with easily-adjustable equipment for changes in spine width and/or adhesive thickness.
- **Use less adhesive** by reducing adhesive thickness and waste while increasing application consistency.
- **Reduce adhesive contamination and cleanup** with closed adhesive systems.

Worldwide Service and Support

Delivery of your new bookbinding application system is just the beginning. Nordson helps protect your investment with exceptional people, programs and service to keep your equipment in peak operating condition.

To assure your satisfaction, all Nordson products and systems are backed by a Package of Values® that includes:

- Service Network
- TrueBlue® Service & Preventive Maintenance Plans
- Global Service & Distribution Centers (Europe, Asia, the Americas)
- Genuine Nordson Replacement Parts
- Repair & Exchange Programs



For more information, talk with your Nordson representative or contact your Nordson regional office.

United States

Duluth, Georgia
Telephone: 800.683.2314
Facsimile: 866.667.3329

Canada

Markham, Ontario
Telephone: 800.463.3200
Facsimile: 905.475.8821

Europe

Erkrath, Germany
Telephone: (49) 211-9205-0
Facsimile: (49) 211-254658

Japan

Tokyo, Japan
Telephone: 81.3.5762.2700
Facsimile: 81.3.5762.2701

Asia/Australia/Latin America

Amherst, Ohio
Telephone: 440.985.4797
Facsimile: 440.985.1096

www.nordson.com/betterbook

Find us on:



Xerox and iGen are registered trademarks of Xerox Corporation.

HP and Indigo are registered trademarks of Hewlett-Packard Development Company, LP.

Nordson Corporation

PAL-12-5745 Reissued 4/12

All rights reserved.

Printed in U.S.A.

© 2004, 2008, 2012 Nordson Corporation

